



TECHNICAL SUBMITTAL DATA SHEET

Leak Detection & Automatic Water Main Shut-Off System

Job Name: _____

Job Location: _____

Engineer: _____

Engineer Approval: _____

Contractor: _____

Contractor Approval: _____

Contractor P.O.: _____

Representative: _____

MODEL RS-080 with 3/4" to 2" Ball Valve

TYPICAL INSTALLATIONS INCLUDE:

- Common-risk housing – condos and apartments
- Commercial break rooms
- New and retrofit construction
- Mechanical rooms

HIGHLY RECOMMENDED FOR:

- Multi-residential complexes
- Commercial office buildings
- Any facility with a history of insurance claims for water damage

FEATURES:

- Full-port valves available from 3/4" to 2" dia.; systems with butterfly valve also available from 2-1/2" to 4" dia.
- Re-useable and testable
- Easy reset button
- Plugs into a standard 120V AC outlet
- Audible alarm (83 dB)
- Supports multiple water sensors for a wider area of leak detection
- N/O and N/C dry contacts
- Factory pre-wired

MODIFIED KIT CONFIGURATIONS:

RS-080-MK6 Plenum-Rated Kit –

Features plenum-rated wires and step-down transformer (120, 208, 240V AC to 24V AC) with mounting plate in lieu of standard wall wart. Ideal for any application that requires a valve installation on a supply line up in the plenum, with power and leak detection sensing in the work space below.



APPLICATION CONSIDERATIONS:

The RS-080 is designed for localized leak detection (one room, one floor, etc.). When a leak is detected, the unit will sound an alarm and automatically shut off the main water supply line, preventing extensive water damage.

INSTALLATION OVERVIEW:

The full-port shut-off valve installs on the main water supply line. The receiver box plugs into a standard 120V AC wall outlet. A sensor is placed in an area where water from a leak is likely to accumulate. Up to 5 additional sensors can be added for a wider area of leak detection. Components come pre-wired.

Optional Cable Adder between the receiver and valve assembly allows the receiver to be located up to 100' from the valve (available in standard 10', 25', 50' and 100' lengths). Ideal for situations where the valve is located in hard to reach locations such as in risers, ceilings, crawl spaces, etc.

The system can be performance tested anytime; it is resettable via reset button on the receiver box. Optional dry contact connections (NO/C/NC) are available for fault notification to existing security panel or BMS.

Emergency manual operation of the valve is accomplished by turning the knob on the top of the actuator. In the event of a power failure, the valve will remain in position (either open or closed).



203-488-2684 or 888-771-4929
 info@RelianceDetection.com
www.RelianceDetection.com

RS-080 with 3/4" to 2" Ball Valve TECHNICAL SUBMITTAL DATA SHEET

ORDERING INFORMATION:

Valve Size	P/N	UPC
3/4"	RS-080-3/4	857640005281
1"	RS-080-1	857640005298
1-1/4"	RS-080-1-1/4	857640005304
1-1/2"	RS-080-1-1/2	857640005311
2"	RS-080-2	857640005328

OPERATING SPECIFICATIONS:

Ball Valve

Pressure Rating 600 WOG - 150 WSP
 Max. Temperature.....366°F

Electric Actuator

Voltage24V AC
 Absorbed Current 1.0 A
 Absorbed Power24V A
 Frequency50/60 Hz
 Working Temp.-4° to 131°F

Receiver Box

Audible Alarm 83 dB

MATERIALS:

Ball Valve

Body Low-lead brass
 End Connection ... Low-lead brass
 Stem..... Low-lead brass
 Ball Low-lead brass
 (tea coated)
 Ball Seats..... PTFE
 O-Rings FKM (Viton®)

CABLE LENGTHS:

Power Cord 12'
 Sensor Cable..... 8' (custom lengths avail.)
 Valve Cable 8' (adder lengths avail.)

APPROVALS:

NSF/ANSI 61 and 372 approved valve.
 MA Board of Registration of Plumbers
 Approval – Code # P3-0818-66.

 UL classified actuator.

DIMENSIONS & WEIGHTS:

Shut-Off
 Ball Valve
 (3/4" to 2") ➔

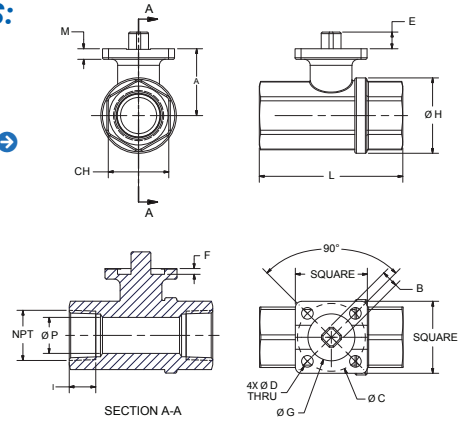

RS-080 Shut-Off Ball Valve Specifications: 3/4" through 2"																		
Size	Square	A	B	C	D	E	F	G	H	I	L	CH	M	P	CV	PSI	LBS	IN-LBS
3/4"	1.50	1.36	0.35	1.42 (ISO F03)	0.24	0.35	0.08	0.98	1.57	0.64	2.99	1.26	0.22	0.75	34.10	580	0.40	53.10
1"	1.50	1.79	0.35	1.42 (ISO F03)	0.24	0.35	0.12	0.98	1.93	0.75	3.54	1.61	0.24	0.95	49.71	580	0.75	53.10
1-1/4"	1.50	1.93	0.35	1.42 (ISO F03)	0.24	0.35	0.12	0.98	2.30	0.84	4.02	1.97	0.24	1.18	102.88	580	1.05	53.10
1-1/2"	1.97	2.52	0.43	1.97 (ISO F05)	0.28	0.43	0.12	1.38	2.87	0.84	4.49	2.17	1.39	1.50	265.88	580	1.73	150.46
2"	1.97	2.88	0.43	1.97 (ISO F05)	0.28	0.43	0.12	1.38	3.60	1.01	5.43	2.76	0.31	1.98	306.34	580	2.98	150.46

(IN-LBS) TORQUE VALVES ARE MEASURED IN LABORATORY TESTS UNDER THE FOLLOWING CONDITIONS: TEMPERATURE: 68°F; PRESSURE: 0 PSI; FLUID: PURIFIED WATER.

Receiver Box ➔

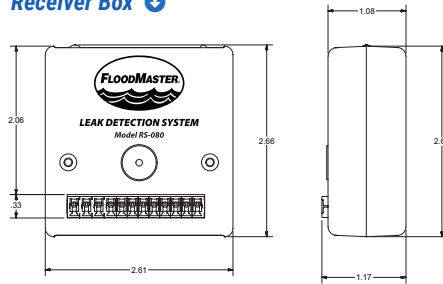

Actuator ➔

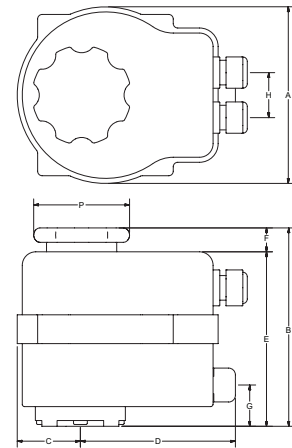

Water Sensor ➔

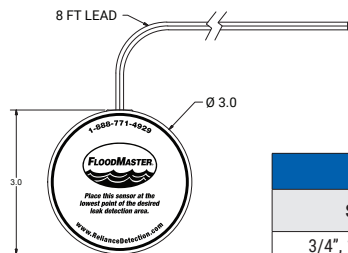

RS-080 Electric Actuator Specifications											
Size	Drilling ISO 5211	A	B	C	D	E	F	G	H	P	
3/4", 1", 1-1/4"	F03-F05	4.84	5.57	1.67	4.74	4.96	0.61	4.06	1.26	0.55	2.68
1-1/2", 2"	F03-F05	6.18	7.40	2.38	5.12	5.75	1.65	1.30	1.42	0.47	2.68

AVAILABLE ACCESSORIES:

- **Wired Sensor Pucks** – Up to 5 additional sensors can be wired to a single RS-080 receiver box for a wider area of leak detection.
- **Sensing Rope Kit** – Ideal for use with low tanks, or for room perimeter and sub-floor leak detection applications.
- **Auto Dialer** – Receive automatic alerts whenever the RS-080 identifies a fault condition.
- **Cable Adder** – Allows for positioning of the RS-080 receiver up to 100' further away from the valve.

RDT recommends that installations be completed by a licensed plumber to ensure that all local code requirements are followed.



Reliance Detection Technologies, LLC
 27 Business Park Drive
 Branford, CT 06405

203-488-2684 or 888-771-4929
 info@RelianceDetection.com
www.RelianceDetection.com